

SERVO DUO GUARD

CRITICAL CARE



HIGHLIGHTS

- For applications in respiratory care and anaesthesia
- Unique dual filter design for safe use during nebulization*
- HEPA filter:
 - Bacterial and Viral efficiency of 99.9999%
 - Special hydrophobic paper gives very low and stable flow resistance in both dry and wet filter
- Electrostatic filter collecting nebulization residuals
- Suitable for all patients
- Disposable - to be exchanged every 24 hours

GENERAL INFORMATION

The Servo Duo Guard is a highly efficient single use bacterial and viral filter for application in respiratory care and anesthesia. The filter provides filtration (bacterial and viral efficiency of 99.9999%) for reducing possible cross contamination between patient and equipment.

The unique dual filter design of the Servo Duo Guard minimizes the risk of sudden increases in expiratory resistance, which is a known problem when using filters during nebulization. This is made possible by combining a high quality HEPA filter for bacterial/viral protection (1) with an electrostatic filter (2) for collecting nebulization residuals from the patient's expired gases.

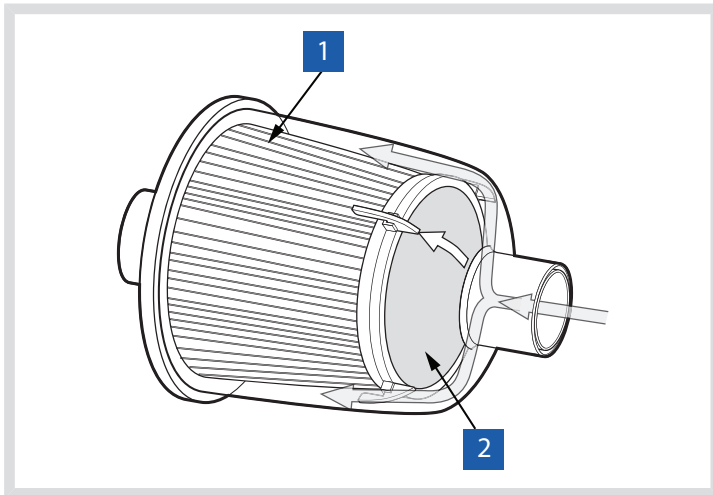

In addition to promoting patient safety, the unique design reduces the need to exchange filters during nebulization, which can potentially:

- Reduce risk of environmental contamination
- Reduce number of times patient circuit is broken
- Reduce total cost for filters over time
- Reduce workload for staff

*The Servo Duo Guard functions properly under the following nebulization conditions:

- Using a drug intended for nebulization (e.g. Berodual, Acetylcystein, Combivent, Garamycin, Pulmicort, Bromhexin, Tacholiquin, Tyloxapol, DNCG Stada).
- Using the Aereoneb or the MAQUET Ultrasonic Nebulizer
- Nebulizing a maximum of 6 times 5 ml (4 ml Pulmicort) during 24 hours, where each nebulization period is ≤ 30 minutes.
- With 24 hour continuous use of single or dual-heated active humidification (100% RH) between nebulization.

The Servo Duo Guard is bi-directional (single direction during nebulization) and can be used on both the expiratory and/or inspiratory limbs of breathing circuits up to 24 hours before being exchanged. The filter housing is transparent to allow continuous inspection during use.

Servo Duo Guard is designed according to ISO standard connections to facilitate connection to different ventilators and anesthesia systems. Each filter is tested individually for filter effectiveness and leakage to guarantee high quality.

COMPARATIVE TEST OF FILTER PERFORMANCE

When nebulizing using a filter on the expiratory limb, a common problem is that the filter gets blocked by residuals from the drug used. Tests comparing disposable HEPA filters, exposed to nebulization, from four of the largest filter suppliers and the MAQUET Servo Duo Guard filter have been carried out.

Test equipment

1. SERVO-i ventilator (MAQUET)
2. MR850 humidifier with single heated circuit (Fisher & Paykel)
3. Test Lung 190 (MAQUET)
4. Aeroneb Nebulizer (Nektar)

Ventilator settings

1. Ventilation mode: Volume Control
2. Tidal volume: 620 ml
3. PEEP: 5 cm H₂O
4. Respiratory Rate: 15 b/min
5. I:E: 1:2

Test method

Two tests were performed, one with Berodual (5ml doses) and one with Pulmicort (4ml doses). To create a challenging test, single heated active humidification was used between nebulizations as the extent to which a drug will block a filter is proportional to the amount of condensation/water in the filter.

Before the first nebulization was initiated the filters were exposed to single heated active humidification for 4.5 hours.

The affect of nebulization on the filters was tested according to the following:

1. A nebulization was started every 4 hours
2. Each nebulization lasted \leq 30 minutes
3. The filter was exposed to single heated active humidification between nebulizations
4. The test was carried out for 24 hours (6 nebulizations in total).

To pass the test the pressure drop over the expiratory limb measured during expiration should not exceed 6cm H₂O.

Results and discussion

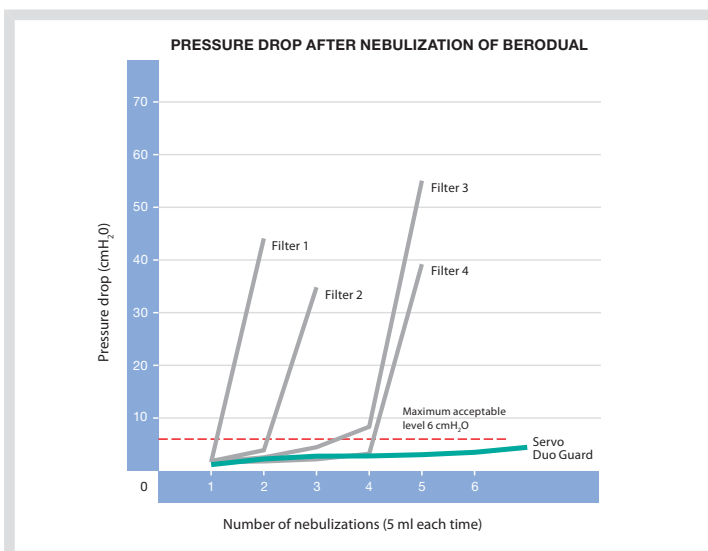

After 1-4 nebulizations all filters except the Servo Duo Guard were blocked, see illustration showing the Berodual test results. This was indicated by a rapid increase of PEEP and measured pressure drops over the expiratory limb between 1285-5505 Pa (~13-56 cmH₂O). As the filters blocked very suddenly (rapid changes within a minute) the risk of harming the patient must be considered if this occurs in a clinical setting. To be able to continue ventilation the filter would have to be exchanged. Similar results were seen when the test with Pulmicort was performed.

Servo Duo Guard out-performed all the other filters and passed the test (see illustration above). After the 6th nebulization the pressure drop measured over the expiratory limb was 3 cmH₂O with Pulmicort and 4.5 cmH₂O with Berodual, see illustration. This clearly indicates that the unique dual design of the Servo Duo Guard makes the filter compatible with nebulization.

TECHNICAL SPECIFICATIONS

GENERAL	
Dimensions	Length = 110 mm, maximum diameter = 78 mm
Weight	< 55 g
Internal volume	170 ml
Filter medium	Hydrophobic HEPA filter (High Efficiency Particulate Air) Electrostatic filter
Pressure	Max. 30 kPa
Leakage	<2 ml/min at 15 kPa over pressure during 5 seconds
Bacterial (BFE) efficiency ¹	99.9999%
Viral (VFE) efficiency ²	99.9999%
Quality check	Each filter is tested individually for filter effectiveness and leakage
Manufacture	Hygienically manufactured and packed (based on ISO 14644-1 and ISO 14644-2)
Environment	Incineration of the device will produce carbon dioxide and water.
Storage temperature	Ambient temperature -25 to +60°C. Relative humidity < 95%.
Shelf life	5 years from manufacturing date, when properly stored in unbroken package
Material	Polypropylene housing, hydrophobic glass fibre paper

RESISTANCE	
Dry filter	<75 Pa (0.75 cmH ₂ O) at 0.5 l/s
	<150 Pa (1.5 cmH ₂ O) at 1 l/s
	<330 Pa (3.3 cmH ₂ O) at 2 l/s
Wet filter	<100 Pa (1.0 cmH ₂ O) at 0.5 l/s
	<200 Pa (2.0 cmH ₂ O) at 1 l/s
	<450 Pa (4.5 cmH ₂ O) at 2 l/s
(Wet filter = 24 hours use at 10 l/min and 100% RH)	

CONNECTIONS	
Coaxial cone male/female	ISO M22/F15 (inlet)
Cone female	ISO F22 (outlet)

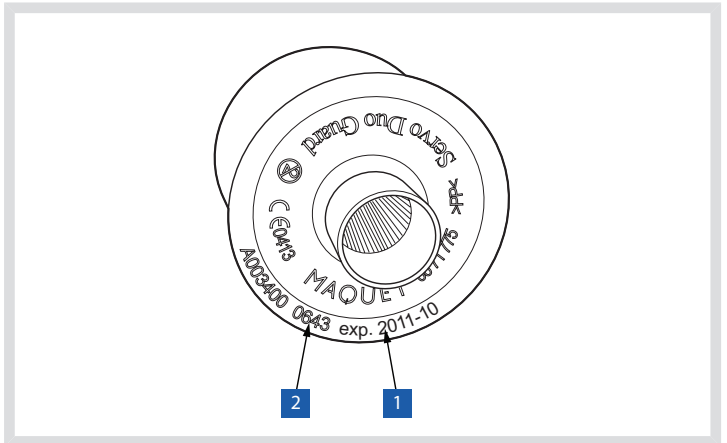

Expiry date yyyy-mm (1) and lot number yy-ww (2) is stated on each Servo Duo Guard as shown in illustration.

REFERENCES

¹Nelson Laboratories. Bacterial Filtration Efficiency Test BFE No 350457, with test values >99.9999%

²Nelson Laboratories. Virus Filtration Efficiency Test VFE No 350467, with test values >99.9999%

ORDERING INFORMATION

Servo Duo Guard: Box of 60 pieces.
Order number 66 71 775.