

Our product reference: 14-1683EU

General product description

LIGHT HANDLE COVER SINGLEPACK 3.75X5.9" –sterile.

This product has 1 PCS plastic disk.

The product is packed in sealed pouch, inner box and outer carton.

General Quality Requirements

Product in compliance with the essential requirements of the Medical Device Directive 93/42/EC As amended by 2007/47/EC, (CE mark) and in conformity with the applicable technical Harmonized standards:

a) Packaging system (only for product delivered sterile)

Primary packaging for sterile products according to requirements of ISO11607-1:2006.

b) Sterilization requirements (only for product delivered sterile)

Sterilization guaranteed for a SAL of 10^{-6} when a validated sterilization process is used and

The integrity of primary package during the shelf life of product is assured.

For this purpose the following standards apply:

ISO11135 -1:2007 for Ethylene Oxide method

c) Biocompatibility requirements

Product is physiologically compatible when used according to its intended purpose.

Based on supplier's information, all materials and components to be in contact with patient or

Medical staff are non toxic and do not lead to any sensitization or irritation effects.

d) Product requirements

Product's general requirements are compliance with EN 13795-1:2002.

Certification & Approval

Doc. Date: 2012-08-02

Distribution: 2 originals, one for Premier Guard and one for Customer

Premier Guard _____ *Name:* Gary Wang *Date:* _____
Office: Quality Manager

Customer _____ *Name:* _____ *Date:* _____
Office: _____

Technical specification

1) Dimensions of the product

Our Reference:	Size
14-1683EU	WxL:3.75X6"

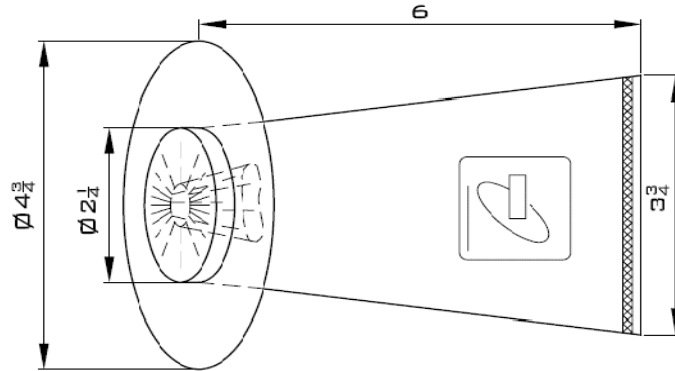

2) Material description

Base material: 41 micron blue PE film
 Other relevant material: plastic disk.

3) Folding specification

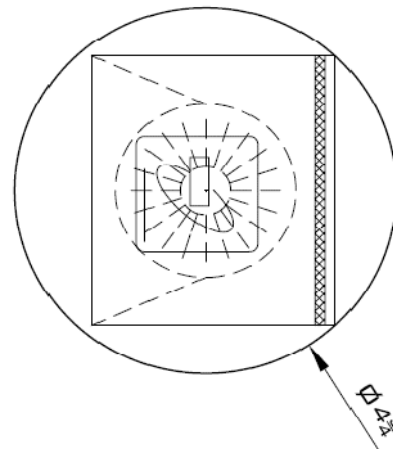

Folding dimensions: 4.75x4.75"

Tolerances:

Folding: +/-1"

4) Packaging specification

Packaging: paper pouch + 11*8.5*10.5" inner box + 17.5*11.8*11" carton

Units per box:

Reference:	Units per box	Units per carton
14-1683EU	50	100