

USER MANUAL

ULT FREEZER

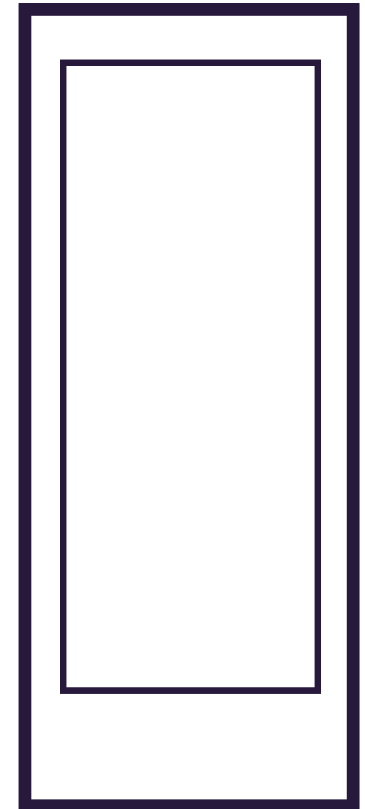

Warning:
Before using this product,
please read this manual carefully
and keep it for future reference.
The design and specifications
are subject to change without
prior notice for product
improvement. Consult with your
dealer or manufacturer for
details.

Table of Contents

1. Safety warnings	01
2. Product Features	07
3. Precautions for Use	08
4. Product Installation	09
5. Product Components and Overview	12
6. Operating Instructions.....	13
7. Alarm Description	20
8. Maintenance and Service	21
9. Troubleshooting and Repair Service	23
10. Specification	24
11. Packing List	25
12. Electrical Schematic Diagram.....	25

Safety warnings

Safety Warning Signs



Warning



Warning:
crushing of
hands



Electrocution
Hazard!



Warning:flammable
material



Warning; low temperature/
freezing conditions, frostbite
HAZARD (MOD)

- ❶ WARNING: The packaging base at the bottom of this series of products must be removed before use.
- ❷ WARNING: When moving this series of products, take care that the bottom foot does not touch the power cord.
- ❸ WARNING: The bottom front wheel brake of this series of products needs to be locked after moving to the designated position.
- ❹ WARNING: This series of products need to be left to stand for 24 hours before initial power-up.
- ❺ WARNING: When this series of products are just connected to the power supply, do not immediately put the items into it. After running for a period of time, when the temperature inside the ULT freezer drops to the set temperature, then put the items in batches.
- ❻ Note: A single batch of items put into the ULT freezer cannot exceed 1/3 of the volume.
- ❼ WARNING: Keep all ventilation openings in the enclosure or, in the structure for building-in, clear of obstruction.
- ❽ WARNING: Do not use mechanical devices or other means to accelerate the defrosting process, other than those recommended by the manufacturer.
- ❾ WARNING: Do not damage the refrigerant circuit.
- ❿ WARNING: Please use grounded power outlets to prevent electric shocks. Ungrounded power outlets must be connected with grounding wires by professional technicians.
- ⓫ WARNING: This ULT freezer must be firmly placed on a solid and flat ground and proper care is taken to prevent overturning.
If the floor is not level or the ULT freezer is placed in an improper location, the ULT freezer may fall down and cause injuries.

- ❶ WARNING: In case of leakage of gas and other flammable gases, open the doors and windows to ventilate and exhaust gas. Do not plug or unplug the power plug of the ULT freezer, otherwise it may cause an explosion and fire.
- ❶ WARNING: Only professional technicians or maintenance personnel for after-sales support can disassemble and assemble the ULT freezer. Otherwise, it may electric shocked to cause a fire.
- ❶ WARNING: Please use the special power supply indicated on the nameplate of the ULT freezer, otherwise it may cause a fire or electric shock.
- ❶ WARNING: The power cord of this ULT freezer is equipped with a three-prong (grounded) plug to mate with a standard three-prong (grounded) outlet of 16A. Never remove the grounding pin of the power cord. Make sure that the power plug and the outlet are connected firmly and reliably, otherwise it may cause a fire.
- ❶ WARNING: When removing the plug from the power socket, you should hold the power plug instead of pulling the wire of the power plug. Otherwise, it may cause electric shock or fire due to short circuit.
- ❶ WARNING: If the ULT freezer is not operating properly, unplug the power plug. It may cause an electric shock or fire if the ULT freezer continues to operate under abnormal conditions.
- ❶ WARNING: Before any repair or maintenance of the ULT freezer, always disconnect the ULT freezer from the power supply to prevent electric shocks or personal injuries.
- ❶ WARNING: Make sure that the drugs or suspended particles inside and around the ULT freezer will not be inhaled during repairs and maintenance, otherwise it may cause harm to human health.
- ❶ WARNING: When storing toxic, harmful, or radioactive substances, please use the ULT freezer in a safe area. Improper use may cause harm to human health or the environment.
- ❶ WARNING: Disconnect the power plug when the ULT freezer is not in use for a long period, so as to prevent electric shock, electric leakage, or fire due to the deterioration of the power cord.
- ❶ WARNING: If the ULT freezer is to be stored unused in an unsupervised area for a long period, ensure that children do not have access to the ULT freezer.

The disposal of the ULT freezer shall be accomplished by the appropriate personnel. Remove doors to prevent accidents such as suffocation.

- ❶ **WARNING:** If CO₂/LN₂ standby system is used, a good ventilation environment must be provided at the installation and use site.
- ❷ **WARNING:** Increased carbon dioxide concentrations in the air can asphyxiate and endanger life safety. In case of poor ventilation, other methods must be considered to ensure a safe environment.
- ❸ **WARNING:** Do not leave the plastic packing bags in a place where they can be reached by small children as this may result in suffocation accidents.
- ❹ **WARNING:** Do not climb on the ULT freezer or put any objects on the ULT freezer, otherwise the ULT freezer may fall and cause injuries or cause damage to the ULT freezer.
- ❺ **WARNING:** Do not use the ULT freezer outdoors. Exposure to rain may cause an electric leakage or electric shock.
- ❻ **WARNING:** Do not place the ULT freezer in a humid location or a place where the ULT freezer is easy to be splashed with water. Otherwise, an electric leakage or electric shocks may be caused by the deterioration of insulation.
- ❼ **WARNING:** Do not pour water directly onto the ULT freezer, otherwise it may cause an electric shock or a short circuit.
- ❽ **WARNING:** Never disassemble, repair, or modify the ULT freezer yourself. Otherwise, fire or personal injuries may be caused by improper operation.
- ❾ **WARNING:** Do not connect the grounding wire to a gas pipe, power supply pip, telephone line, or lightning rod when grounding the ULT freezer. The above grounding methods will cause electric shocks or other hazards.
- ❿ **WARNING:** Do not touch any electrical parts such as the power plug or operate any switch with a wet hand, otherwise it may cause an electric shock.
- ⓫ **WARNING:** Do not put water containers or heavy objects on the ULT freezer. Falling objects may cause personal injuries and spilled water may cause the insulation to be reduced and result in an electric leakage or electric shock.
- ⓬ **WARNING:** Never insert metal objects such as iron nails and wires into any vent, gap, or air outlet on the ULT freezer. This may cause electric shocks or injuries by accidental contact of these objects with moving parts.

- ❗ WARNING: It is not allowed to tie, drag, pull, wind and bind the power cord, or damage the power cord plug. Damaged power cords or plugs may cause fire or electric shock.
- ❗ WARNING: The power cord with a loose plug is not allowed, because it may cause fire or electric shock.
- ❗ WARNING: It is not allowed to put glass bottles or canned items in the ULT freezer, which may be frozen and cracked, causing injury to personnel.
- ❗ Refrigerant and cyclopentane foaming material used for the appliance are flammable. Therefore, when the appliance is scrapped, it shall be kept away from any fire source and be recovered by a special recovering company with corresponding a qualification other than being disposed of by combustion, so as to prevent damage to the environment or any other harm.
- ❗ IMPORTANT: Flammable gas and refrigerant used. It is the consumer's responsibility to comply with Federal and Local regulations when disposing of this product. Suggestion: Cut off the pipeline and drain the refrigerant without any open fire around.



The product with this symbol reads "warning terms";



The product with this symbol reads "prevent fire, stay away from fire sources";

CYCLOPENTANE

The product with this symbol reads "cyclopentane blowing"

- Power supply voltage: This series of products use 220V-240V/50Hz AC power supply, if the use of voltage lower than 198V or higher than 264V, need to add a suitable automatic voltage regulator with the use (5kVA).
- Use of this series of products requires a low-voltage air circuit breaker and earth leakage protection device for the power supply.
- A special power socket must be used and reliable grounding must be carried out, and the length of the power line must not be arbitrarily extended. If extensions are required, copper-core conductors with a cross-sectional area of 2.5mm² or more must be used, and copper-core conductors in the wall connected to the power socket must also have a cross-sectional area of 4mm² or more.
- This series of products are strictly prohibited to put into flammable, explosive

dangerous goods and strong corrosive acid, alkali and other items;

- The keys of this series of products need to be properly stored to avoid accidents when children get them and open the door to play;
- Do not connect the neutral wire (N terminal) and the ground wire (E terminal) of the power socket together, otherwise it can cause the shell of this series of products to be charged and an electric shock accident can occur;
- The power cord cannot be bundled and used, cannot be pressed under heavy objects, and cannot be close to heat sources such as compressors.
- When it needs to restart the ULT freezer after the ULT freezer is unplugged or the power to the ULT freezer is interrupted, check the settings of the ULT freezer.

Items stored inside the ULT freezer may be adversely affected if the operation of the ULT freezer is resumed with changed settings.

- If the ULT freezer is unplugged or the power to the ULT freezer is interrupted, do not restart the ULT freezer for at least 5 minutes to avoid damage to the compressor or system.
- The filter screen shall be checked in time and cleaned. Dust-laden filter screens can cause temperature rise or failure in the ULT freezer.
- If the power plug has dust, it needs to be cleaned in time. Improper connection or plug filled with dust may cause heating or ignition.
- After the power is cut off or the power switch is off, the set point shall be checked when the power switch is restarted; otherwise, the stored items may be damaged due to setting change.
- Wear gloves during maintenance to avoid personal injuries caused by touching sharp edges or corners.
- The stored items shall not be contacted directly by hand. Direct contact with the frozen items or the inner wall of the ULT freezer without gloves may cause frostbite.
- Close the door by holding the handle to prevent fingers from being pinched.
- Tilt the ULT freezer for 45° when handling or moving it.
- Be careful not to trip over the ULT freezer when handling the ULT freezer, so as to prevent damage to the ULT freezer or personnel injuries.
- Do not use door handles to lift or carry equipment to prevent damage to the ULT

freezer or personnel injuries.

- Do not use electrical appliances inside the storage compartment of the ULT freezer, unless they are of the type recommended by the manufacturer.

Product Features

This product is mainly used to preserve drugs, vaccines and reagents.

It is applicable to hospitals, epidemic prevention stations, universities, scientific research institutes and electronic chemical industry enterprise labs.

Product Function

Precision temperature control Data traceability

- Computer temperature control, with a display accuracy of 0.1°C
- The temperature in the ULT freezer is uniform and controllable, the temperature range is adjustable to -86°C~-40°C, and the temperature control is accurate
- Standard USB port and traceable temperature data; query and save temperature data at any time

Efficient refrigeration Effective thermal insulation

- Imported compressor has the self-overlapping refrigeration and strong refrigeration capacity, and is safe and reliable
- High-performance VIP thermal insulation layer has the good thermal insulation effect
- Multi-layer 3D seal design effectively reduces refrigerating capacity loss and frosting

Multiple alarms Safety and stability

- Ideal function of audible and visual alarms to realize functions such as alarms for high and low temperature, power failure, and sensor fault; users may set the alarm temperature as needed
- Design of safety door lock improves the safety level of sample management

User-friendly design

- Adjustable shelf design ensures storage space available as required
- The LCD touch screen can be configured, with OTA function, displaying the temperature inside the ULT freezer and ambient temperature, and setting the high and low temperature alarm values and the ULT freezer temperature values as required, with the function of fault warning and early warning.

Note: The above features are not available for all models of products, and the detailed configuration shall be subject to the specific functions of each model.

Due to the continuous optimization of the product, the product you obtained may not be exactly consistent with the instructions. We sincerely apologize for this.

The contents of the manual are subject to change without prior notice.

Precautions for Use

- ★ When the ULT freezer is running, the contact part between the front of the ULT freezer and the outer door may be heated, which is not a fault. In order to prevent condensation around the ULT freezer housing, the heating condensate pipe is installed.
- ★ Before storing items in the equipment, check that the temperature in the storage compartment reaches the set temperature and then store the items in batches. The volume of each batch of items to be placed in the ULT freezer shall not exceed 1/3 of the volume inside the ULT freezer to prevent excessive temperature rise.
- ★ The displayed equipment temperature is the temperature at the temperature sensor in the storage compartment. There is a certain difference between the temperature displayed at the beginning of the operation of the equipment and the actual temperature in the center of the equipment, but as the equipment enters a stable state, the displayed temperature will gradually approach the actual temperature.
- ★ An inspection hole is installed on the enclosure of the equipment to pull out the testing line in the ULT freezer during the testing. After the testing line is pulled out, it is necessary to plug the testing hole again with thermal insulation material, otherwise the temperature in the ULT freezer may not reach the set temperature and cause condensation around the outside of the hole (applicable to ULT freezers with testing holes).
- ★ Please clean the equipment with a diluted neutral detergent. Do not use brushes, acids, gasoline, soap powder, polishing agents, or hot water for cleaning, otherwise the painted surface and plastic rubber parts may be damaged. Pay extra attention to not wipe plastic and rubber parts with volatile solvents such as gasoline.
- ★ When the ULT freezer is not in use for a long period, cut off the power supply and turn off the battery switch.
- ★ If the ULT freezer is not started again for a long time, a low battery level may occur. After the battery switch is placed at "ON", the battery can be charged, and the ULT freezer can run continuously for about one week to charge the battery (applicable to models with batteries).
- ★ Please minimize the time of opening the door during each access to the items, so as not to cause great fluctuations in the temperature and humidity in the ULT freezer.
- ★ After the door is opened, the temperature in the ULT freezer will rise sharply in a short time, which is normal, and it will return to set temperature of normal operation after the door is closed.
- ★ After the ULT freezer has been running for a period of time, a layer of frost is formed on the inner wall and inner door of the ULT freezer. If the frost layer is too thick, it will affect the thermal insulation effect of the ULT freezer and increase the power consumption. Therefore, after the frost layer reaches 5 mm, the attached shovel shall be used to defrost.
- ★ Before defrosting, the frozen items in the ULT freezer shall be taken out with ice shovel and put in a suitable environment for storage, to not damage the items due to temperature rise in the ULT freezer.
- ★ There are many refrigerating coils behind and on the side of the inner wall. The frost from the inner wall shall not be removed by sharp tools such as knife, ice chisel or screwdriver. The inner wall shall not be scratched during defrosting, or the ULT freezer will fail.

Product Installation

Installation Environment

- ★ Ambient temperature: 10 °C~32 °C; ideal temperature: 18 °C~25 °C; air conditioning system shall be used if necessary.
- ★ Ambient humidity: less than 80%Rh. The humidity shall be less than 60% Rh if the maximum operating temperature is 32 °C.
- ★ Avoid large amounts of dust.
- ★ Avoid mechanical sway or vibration.
- ★ Altitude of working position of ULT freezer: lower than 2000m.
- ★ Input voltage: 220V~240V, with a fluctuation within 10%.
- ★ Over-voltage level: II, Capacitance: 5KVA, IPX0.
- ★ Pollution level: 2.
- ★ The ULT freezer is sensitive to ambient temperature. If installed in an environment other than the above, the ULT freezer cannot operate normally. Please improve the environment before use.
- ★ Do not install the ULT freezer outdoors. Exposure to rain may cause an electric leakage or electric shock.
- ★ Transportation and storage conditions: Ambient temperature -40°C~+55°C, humidity 10~90% Rh

Installation Location

- ★ It shall not be installed in a narrow and closed space. The door body of the room where the ULT freezer is placed shall not be smaller than or lower than the ULT freezer, or at least the normal access of the equipment shall be ensured, so as to avoid maintenance difficulties in the event of equipment failure and causing damage to the stored items due to failure of repairing the equipment in time.
- ★ The floor on which the ULT freezer is installed must be sturdy and flat, non-flammable, and capable of bearing the weight of the equipment during operation.
- ★ The ULT freezer shall be installed in a well-ventilated location and not exposed to direct sunlight.
- ★ Each ULT freezer shall be provided with an independent power outlet. Please ensure that the outlet is capable of bearing a current $\geq 16A$, and the plug is firmly connected with the outlet. The power cord shall not be twisted or pressed.
- ★ Check the operating voltage before use. A voltage stabilizer suitable for the equipment load shall be considered to be used in areas with unstable voltages for voltage stabilization, and the power of the voltage stabilizer shall be greater than 4000W to ensure that the requirements for the input voltage in the installation environment are met.
- ★ The equipment shall be reliably grounded. If the power outlet is grounded, check whether it is properly grounded before use. If the outlet is ungrounded, it must be grounded by professional engineering technicians.



WARNING

- ★ Do not connect the grounding wire to a gas pipe, water pipe, telephone line, or lightning rod when grounding the unit, otherwise it may cause an electric shock.
- ★ After installation, the power plug must be accessible to facilitate timely unplugging of the power cord in case of emergency. Do not block the vent of the ULT freezer.



CAUTION

- ★ As the ambient temperature has a great impact on the equipment, if the above environmental requirements cannot be met, the equipment may not operate normally. Please improve the environment before using the equipment. The equipment operates intermittently.

Preparation before Use -----

- 1 Remove all transport packaging materials and belts.
- 2 Check the accompanying accessories. Please check the items in the box with reference to the packing list. If there is any discrepancy, please contact for after-sales service in time.
- 3 The placement conditions shall be such that clearances of at least 30cm are reserved around the ULT freezer for ventilation and heat dissipation.
- 4 Rotate the horizontal supporting feet clockwise with a wrench or manually to extend downward so that they are supported on the ground to ensure that the ULT freezer does not move when used.
- 5 Open the outer door by more than 90°, take out the shelf from the bottom of the ULT freezer, remove the shelf protective film, and place the shelf one by one on the shelf support strip.



WARNING

- ★ Do not leave the plastic packing bags in a place where they can be reached by small children as this may result in suffocation accidents.

Initial Start -----

When using the equipment for the first time, please follow the following steps:

1. After the equipment is placed, leveled and cleaned, keep the ULT freezer still for more than 24 hours before connecting it to the power supply, so as to ensure the normal operation of the equipment.
2. Connect the power cord to a dedicated outlet of suitable specification under no load condition.
3. After the power supply is turned on, turn on the power switch of the equipment first; if the equipment is equipped with a battery, turn on the battery switch again (at the bottom of the rear side of the ULT freezer).
4. Set time parameter after the power supply is turned on.
5. Set the required temperature, do not put anything in the empty ULT freezer, power on and start up, check whether the operating temperature of the equipment reaches the required temperature, observe the normal startup and shutdown of the equipment for more than 24 hours, and demonstrate that the performance of the ULT freezer is normal.
6. Please store the items in batches, with the volume of each batch of items to be placed in the ULT freezer not exceeding 1/3 of the volume inside the ULT freezer. Ensure that the equipment is shut down and operates normally after being switched on and off for more than 8 hours before placing the next batch of items.
7. The door opening shall be minimized during the cooling process, otherwise the temperature will rise.

Operation after Power Failure

The set value is memorized by the equipment. After recovery from a power failure, the equipment will resume operation with the setting parameters before the power failure.



- ★ If the ULT freezer is unplugged or the power to the ULT freezer is interrupted, do not restart the ULT freezer for at least 5 minutes to avoid damage to the compressor or system.



- ★ When the ULT freezer is not in use for a long period, unplug the power plug and turn off the battery switch (applicable to ULT freezers with batteries) to prevent electric shock, electric leakage, or fire due to the deterioration of the power cord.
- ★ If the ULT freezer is to be stored unused in an unsupervised area for a long period, ensure that children do not have access to the ULT freezer and that doors cannot be closed completely.



- The product shall be managed by a specially-assigned person to check the operation and make records every day (it is recommended to record the inspection once every 2~4 hours). In case of failure or shutdown, the temperature in the ULT freezer will rise. If it cannot be repaired in a short time, the articles shall be transferred to other places that meet the temperature requirements for storage to avoid damage to the articles.
- This product is a ULT freezer. Please confirm in advance that the temperature required for the stored articles is consistent with the temperature range of the ULT freezer to avoid damage to the stored articles due to mismatch of the temperature range.
- Due to the inertia of refrigeration, there is a certain difference between the displayed temperature and humidity of this product and the actual temperature and humidity inside the ULT freezer, which is normal.
-  • Since all ULT freezers are storage equipment, it is strictly prohibited to put too many relatively hot items at one time, which will cause the compressor to not stop for a long time, the temperature will drop slowly and affect the service life of the compressor. The items must be put in batches to allow the temperature to decrease by steps until the required temperature is reached!
- Do not damage the refrigerating circuit.
- Do not use electrical appliances without production permits inside the ULT freezer.
- No mechanical tools or other means without the manufacturer's permission shall be used to accelerate the defrosting process.

Product Components and Overview

Appearance Diagram

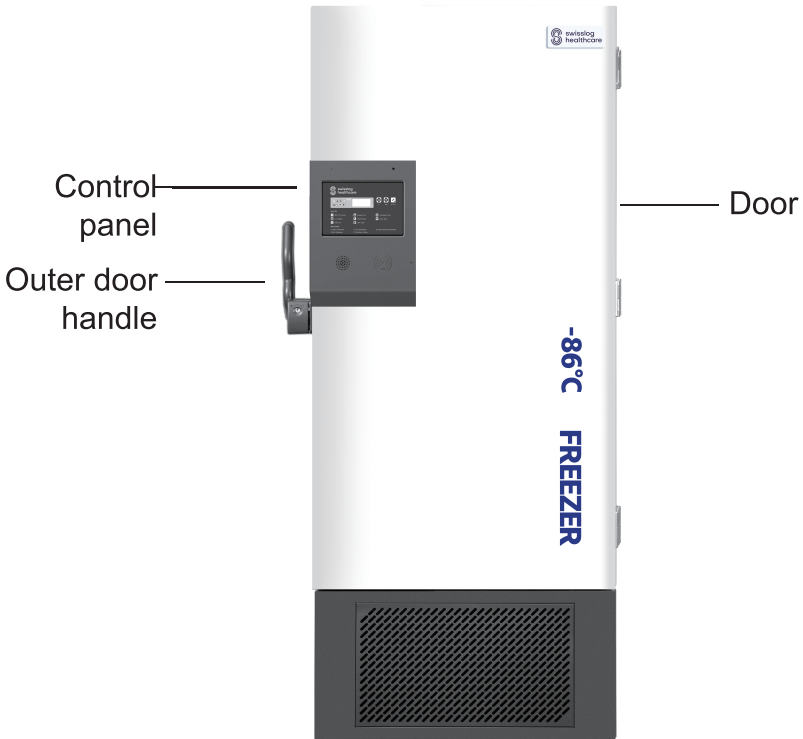

Due to product improvement and differences among models, the actual product may be different from the diagram. Please refer to the actual product! The schematic diagrams are only for brief description of functional parts.

Operating Instructions

1. Operating and Display Panel

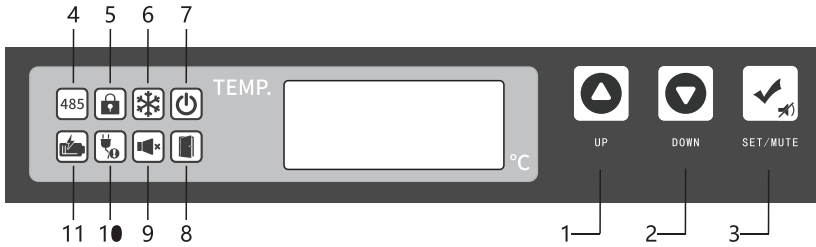

2. Description of Keys and Icons

Key 1 - UP key

Key 2 - DOWN key

Key 3 - SET/MUTE key

Icon 7 - Power state

Icon 5 - Key locked

Icon 6 - Compressor running

Icon 8 - Door opening state

Icon 8 - Door opening state

Icon 9 - Mute state

Icon 10 - Power-off state

Icon 11 - Power-off state

3. Key Operation

Every time the equipment is powered off and re-energized, it is necessary to reset the year, month and day parameters. For the setting method, please refer to Section 3.7 "Time Setting Function Operation" below.

1) Function of keypad lock

a) When the key is not locked, press "UP" key and "DOWN" key at the same time until the buzzer sounds twice and then release it or do not conduct key operation for 60 seconds. The key will be locked, and icon 5 will be lighted;

b) When the key is locked, press "UP" key and "DOWN" key at the same time until the digital tube displays "0000", then release them, adjust the display to 0005 through "UP" key, and then press "SET/MUTE" key to return to normal display. The buzzer will sound once and icon 5 will go out.

2) Check the ambient temperature

After pressing "SET/MUTE" key, the digital tube will display the ambient temperature. And it will return to normal display without key operation for 5 seconds.

3) User parameter setting

When the key is not locked, press and hold "SET/MUTE" key until the digital tube displays "MAX", and then release it. Press "UP" key or "DOWN" key to switch to other menus (menu items are shown in the table below). Press "SET/MUTE" key to adjust the corresponding parameters of this menu. If no key is pressed for 60 seconds, or press and hold the "SET/MUTE" key until the buzzer sounds once, the program will save the parameters and exit.

The user menu is as follows:

Menu	Menu Description	Setting Range	Default	Unit
MAX	Maximum temperature in the current period	---	---	°C
MIN	Minimum temperature in the current period	---	---	°C
CLR	Clear the maximum and minimum temperature records in the current time	0: Clear 1: Do not clear	0	/
Set	Temperature settings	-86.0~-40.0	-86.0	°C
H	Upper deviation of high temperature alarm	0.0~10.0 0: Cancel the alarm	10.0	°C
L	Lower deviation of low temperature alarm	0.0~10.0 0: Cancel the alarm	10.0	°C
n	View current date - year	--	--	/
y	View current date - month	--	--	/
r	View current date - day	--	--	/
S	View current date - hour	--	--	/
F	View current date - minute	--	--	/
Pt	Printing interval	0~240	20	min
tH1	High ambient temperature alarm value	20.0~80.0	36.0	°C
PS1	User menu password setting	0000~9999	0005	/
b1	Hardware version	--	2.0	/
b2	Software version	--	2.1	/

4) Start the recorder

If the digital tube flashes to display "LoF", unlock the key firstly (see the unlocking function in 3.1), and then press and hold "UP" key and "SET/MUTE" key at the same time until the buzzer rings three times, and the digital tube will stop displaying "LoF". Automatic export of USB data

5) Automatic export of USB data

a) When the USB flash disk is connected to the USB port, the buzzer will buzz once, and the screen will display the code "on" (in case of large data volume) of data upload. PDF files with the data of the current and the last months will be generated and imported into the USB flash disk. After the data transmission is completed, the buzzer will buzz once, the screen will display "End" and return to normal display after 6s. Note: When the data is less, the digital tube will not display "on" and "end" prompts.

b) When the USB flash drive has been connected to the recorder module, data will be imported to the USB flash drive every other month to generate a pdf file of the data for the current month. The buzzer will beep once and the digital tube will show the data upload code "on" (in case of large amount of data). After the data transmission is completed, the buzzer beeps once and the digital tube displays "End", and the digital tube resumes normal display after 3s.

Note: The USB flash disk is required to be formatted first. The file system of the USB flash disk is in FAT32 format, with a capacity of not more than 32G bytes, and the USB flash disk cannot be partitioned. Please use USB flash disks of mainstream brands, such as sandisk and Kingston.

6) Manually generate PDF files

When the key is not locked and the USB flash disk is connected properly without conducting file generation, press and hold "UP" key "d01", press "UP" key or "DOWN" key to adjust "d00~d12", press "SET/MUTE" key to generate a PDF file of recorded data in the previous month (1~12), and this file inside the USB flash disk will be canceled when it is adjusted to d0 0.

7) Time setting function

Every time the equipment is powered off and re-energized, the digital tube displays "n". Press "UP" key or "DOWN" key to display the corresponding parameters in the following table in turn:

n	YY	/
y	MM	/
r	DD	/
s	hr	/
F	min	/
Pt	Printing interval	20
SCY	Data recording interval	10

Modify "n" operation example

Steps	Operation	Digital Tube Display
1	Digital tube display "n"	n
2	Press "SET/MUTE" multi-function key	/
3	Press "UP" key and "DOWN" key to adjust the parameter value to the target year	e.g. 2023, adjust to 23
4	Press "SET/MUTE" multi-function key to save parameters	/

Modify "y" operation example (refer to this example for other modifications of "r", "s", "F", "Pt" and "SCY")

Steps	Operation	Digital Tube Display
1	Digital tube display "n"	n
2	Press the Up and Down buttons to select the parameter "y" to be adjusted;	y
3	Press "SET/MUTE" multi-function key	/
4	Press "UP" key and "DOWN" key to adjust parameter value to target month	/
5	Press "SET/MUTE" multi-function key to save parameters	/

Please complete the setting within 2 minutes. If there is no need to change the time, you can press and hold "SET/MUTE" key for 3 seconds to exit or automatically exit after 2 minutes to restore normal display. Please export the previous data records before powering off the whole machine, otherwise it may lead to loss of data records or time disorder. Please export the previous data records before changing the recorder time and recording interval settings, otherwise the data records will be lost.

8) Temperature recording

The temperature data is stored once every 10 minutes by default.

Tips: The battery switch needs to be turned on during the use of the product, and the functional configuration of the product is different. Please refer to the actual configuration.

4. Printer (optional)

Automatic printing

When the printing interval Pt is not 0, the printer will automatically print the current data every Pt minutes.

Note: The printing interval " Pt " shall be set as an integral multiple of the recording interval " ScY " (at present, both Pt and ScY are 10 minutes by default).

Manual printing

When the key is not locked, press and hold "DOWN" key until the digital tube displays "P01". Press "UP" key or "DOWN" key to adjust the setting range "P01~P07", and press "SET/MUTE" multi-function key, the printer will print the recorded data of the currently previous days (1~7 days).

The printer uses $44\pm 0.5\text{mm}$ or $57.5\pm 0.5\text{mm}$ wide ordinary paper rolls, and the general process of paper loading is as follows:

(1) As shown in Figure 2-2, hold the two hooks indicated by arrows in the figure and pull them outward to open the cover of the printer.

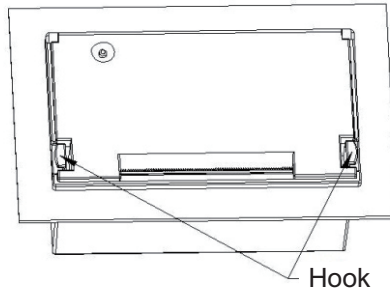

Fig. 2-2

(2) Hold both ends of the paper shaft shown in the figure below and take out the paper shaft, as shown in Figure 2-3.

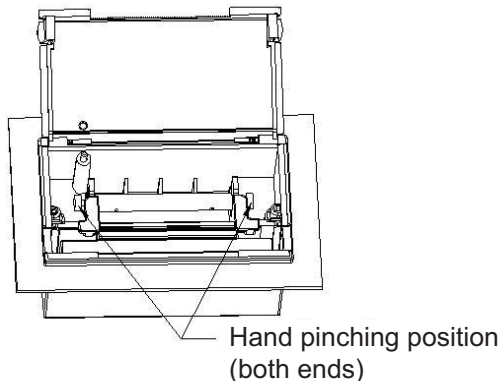

Fig. 2-3

(3) Load the paper roll into the paper shaft according to the direction shown in Figure 2-4, hold both ends of the paper shaft, put the paper roll into the paper compartment, loosen the paper shaft and clamp it tightly.

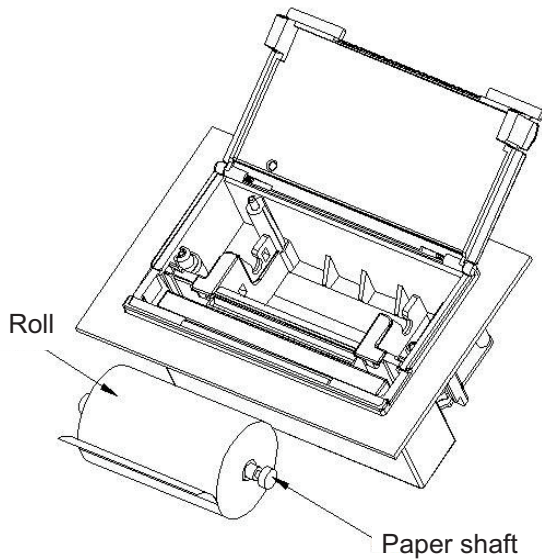

Fig. 2-4

(4) Turn on the power, press the paper feeding key to feed the paper from the paper inlet, and after the paper comes out of the paper outlet, press the paper feeding key again to stop feeding. As shown in Fig. 2-5:

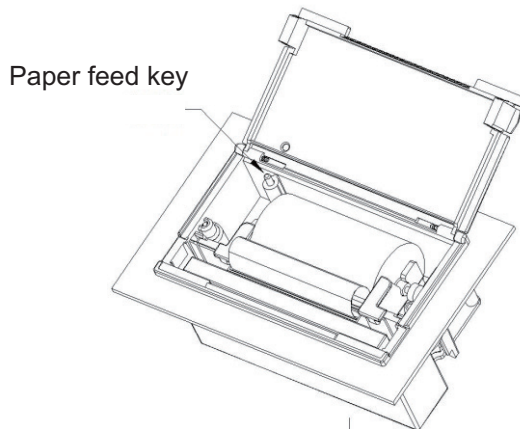

Fig. 2-5

(5) After the inner shell is completely pushed in and clamped tightly with the outer shell, paper loading is completed. As shown in Fig. 2-6:

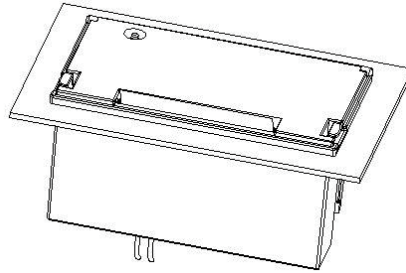

Fig. 2-6

Notes:

1. When the paper roll is fluffy until its highest point exceeds the upper cover of the printer, it will cause paper jam. At this time, wind up the paper roll tightly in the direction shown in Fig. 2-7 and then close the upper cover.

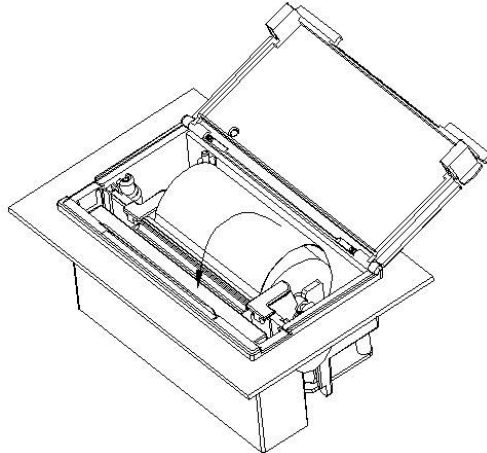

Fig. 2-7

2. When the inner shell cannot be pushed inward, please pull it out and try to push it in again. Do not operate vigorously to avoid damaging the printer.

Alarm Description

SN	Alarm Code	Meaning
1	H1	Alarm for high temperature inside the freezer
2	L1	Alarm for low temperature inside the freezer
3	H2	High ambient temperature alarm
4	H3	Alarm for high condenser temperature
5	Do	Door opening alarm
6	PF	Power failure alarm
7	bL	Low battery alarm
8	E1~E4	Sensor fault alarm
9	Er	USB data recorder fault alarm

Maintenance and Service



- i Always cut off the power supply before any repair and maintenance of the equipment to prevent electric shocks or personnel injuries.
- i Make sure that drugs or suspended particles from the surrounding environment will not be inhaled during equipment maintenance. Otherwise it may cause harm to human health.



- i Do not spill water directly on the freezer body to avoid reduced insulation performance of electrical components and rusting of metal parts.
- i Do not use hot water and corrosive cleaners or organic solvents to clean the freezer body.
- i Do not put heavy objects on top of the equipment to avoid deformation of the equipment due to pressure.

Cleaning of Biomedical Freezer

- 6 The biomedical freezer should be cleaned once a month. Regular cleaning keeps the biomedical freezer a brand-new appearance.
- 6 Wipe the dust off the biomedical freezer's shell, inner chamber, and all accessories with a dry cloth. If the biomedical freezer is dirty, wipe it with a cleaning cloth soaked with a neutral detergent to remove the dirt and wipe off the residual detergent with a wet cloth. Then, wipe it with a dry cloth again.
- 6 Do not pour water onto the biomedical freezer shell or into the biomedical freezer. Otherwise, it may damage the electrical insulation, leading to a failure.
- 6 The compressor and other mechanical parts are completely sealed and do not require lubrication.
- 6 Clean the frost or ice on the inner wall and the condenser filter screen once a month.

Cleaning of Condenser Filter Screen

The filter screen shall be cleaned once a month under normal use. If the filter screen is blocked, the refrigeration effect of the freezer will be affected and the service life of the product will be reduced. Please clean the filter screen as follows.

1. Remove the front bottom hood and the filter screen.
2. Clean the filter screen with water.
3. Blow off the dust on the condenser with compressed air.
4. After the filter screen is dried, put it back to its original position and install the hood.

Note: The configuration of different product models is different, please refer to the actual product.

Inner Wall Defrosting

Frosting may cause a gap between the biomedical freezer and the door sealing strip, resulting in poor refrigeration. The inner door shall be defrosted with an ice shovel attached to the biomedical freezer. The following steps are natural defrosting.

1. Shut down the auxiliary cooling device if any.
2. Remove items from the biomedical freezer and transfer them to an environment suitable for storage.
3. Turn off the power switch
4. Open the outer and inner doors to allow the ULT freezer to open naturally for a period of time for defrosting.
5. Dry the accumulated water at the bottom of the biomedical freezer with a piece of dry cloth.
6. After cleaning the biomedical freezer and inner door, restart the biomedical freezer.
7. Put the items back into the fully cooled biomedical freezer.
8. If there is an auxiliary cooling device, restart the device.



Do not use knife, screwdriver or any other tool with a sharp edge to defrost.

Equipment Out of Service

Out of service: If the biomedical freezer is to be stored unused in an unsupervised area for a long period, ensure that children do not have access to the biomedical freezer and that doors cannot be closed completely.

Scrap: The scrapping disposal of the biomedical freezer shall be carried out by corresponding professionals. In order to prevent something like suffocation, the biomedical freezer doors must be removed.

Optional Accessories

Temperature Recorder

Please refer to the Temperature Recorder Instructions provided by the temperature recorder for use.



Please install the temperature recorder by professional technicians or after-sales personnel.



Please cut off the power supply before installing the temperature recorder; otherwise, electric shock or fire may occur.

Freezer Rack and Box

When the freezer stores small specifications of materials, freezer rack and box can make more efficient use of space. The height of the rack may need to be properly adjusted.

Troubleshooting and Repair Service

Any product may fail. Please observe the operation of the equipment in time during use. If there is any abnormality, please check and handle it according to the table below. If the problem cannot be solved, inform our Service Center in time, and we will do our best to help you and avoid any loss.

National
service hotline
400-689-2020

Fault	Troubleshooting Method
Biomedical freezer does not work	Is the power circuit breaker normal?
	Is the power voltage too low?
	Is the power switch off?
	Is the fuse blown?
Poor cooling	Is the ambient temperature too high?
	Is the inner door closed tightly? Is the outer door closed tightly? (The frost between the biomedical freezer and the door sealing strip may damage the door sealing performance)
	Is the air inlet dirty and blocked?
	Are the condenser and filter screen dirty and blocked?
	Whether the humidity is set correctly
	Is the biomedical freezer away from direct sunlight?
	Is the biomedical freezer close to the heat source?
	Are the rubber hole cover and insulation material of the test through hole properly placed?
	Are a large amount of high temperature articles placed in the biomedical freezer for a short time?
Excessive noise	Is the biomedical freezer installed on a solid and flat ground?
	Are other items contacted to the biomedical freezer housing?
	Is the base of the biomedical freezer leveled?

 Note: If the fault cannot be eliminated after the above items are checked, or the fault is different from the above list, please contact the after-sales personnel.

Specification

Name	Biomedical Freezer				
Model	SLHC-MD 86L358	SLHC-MD 86L458	SLHC-MD 86L568	SLHC-MD 86L718	SLHC-MD 86L838
Climate type	N				
Type of protection against electric shock	Class I				
Power supply	220V-240~/50Hz				
Temperature in tank	(-86 ~ -40)°C				
Refrigerant	Mixed				
Refrigeration mode	Direct cooling				
Foam material	Cyclopentane				
Total effective volume (L)	358	458	568	718	838
Rated power (W)	950	1190	2210	2210	2030
Rated current (A)	5.3	5.9	12	12	9.5
Weight (KG)	160	237	286	305	332
Product dimensions (W * D * H) mm	795*885 *1855	885*855 *1980	885*995 *1980	1030*995 *1980	1175*995 *1980

Description of technical parameters: The technical parameters in this table are measured under standard conditions. After the parameters are changed due to product improvement and technical update, no further notice will be given, which shall be subject to the nameplate attached to the biomedical freezer.

Packing List

Name	Instructions	Defrosting shovel	Key	Gloves	Warranty Card and Certificate of Conformity
Quantity	1 copy	1 pcs.	2 pcs.	1 pair	See the last page of the Instructions

Note: External padlock and handle optional accessories shall be subject to physical configuration.

Electrical Schematic Diagram

1.SLHC-MD-86L358

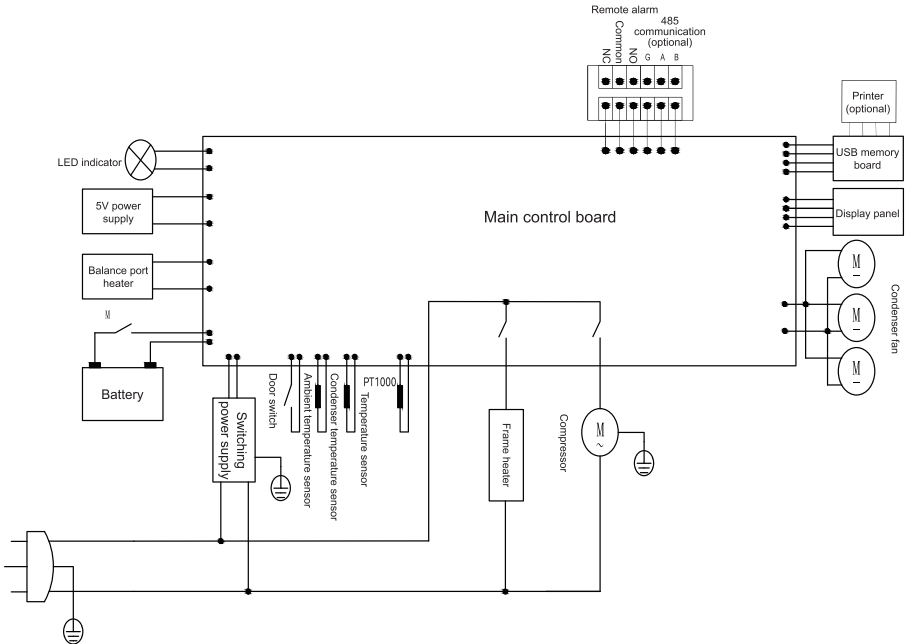

2.SLHC-MD-86L458

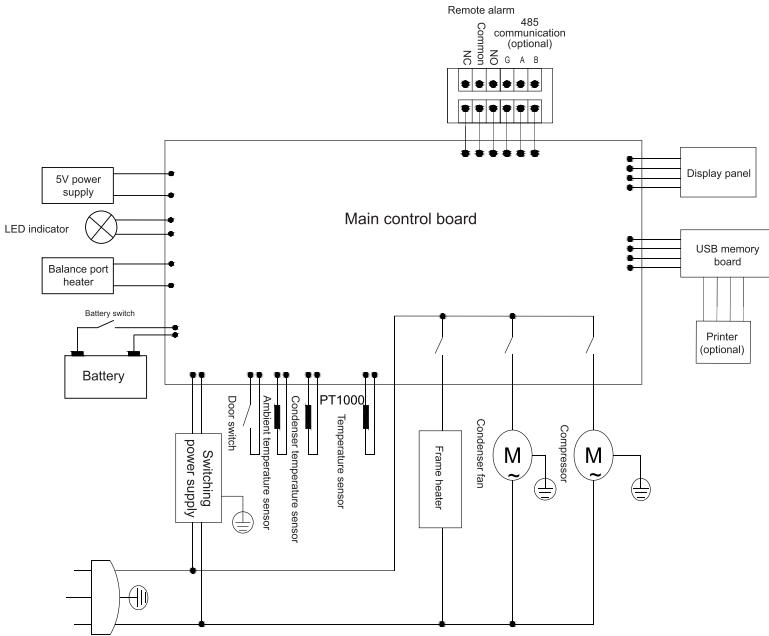

3.SLHC-MD-86L568/SLHC-MD-86L718

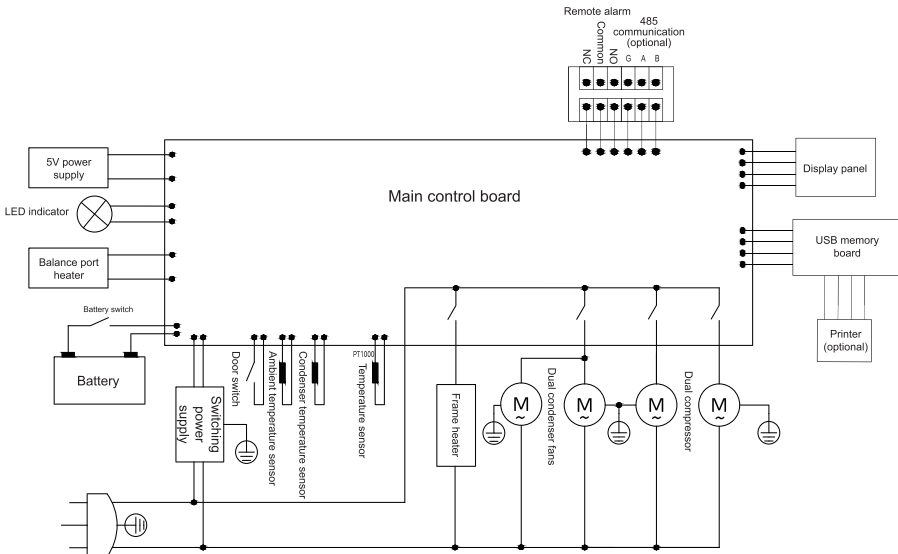

4.SLHC-MD-86L838

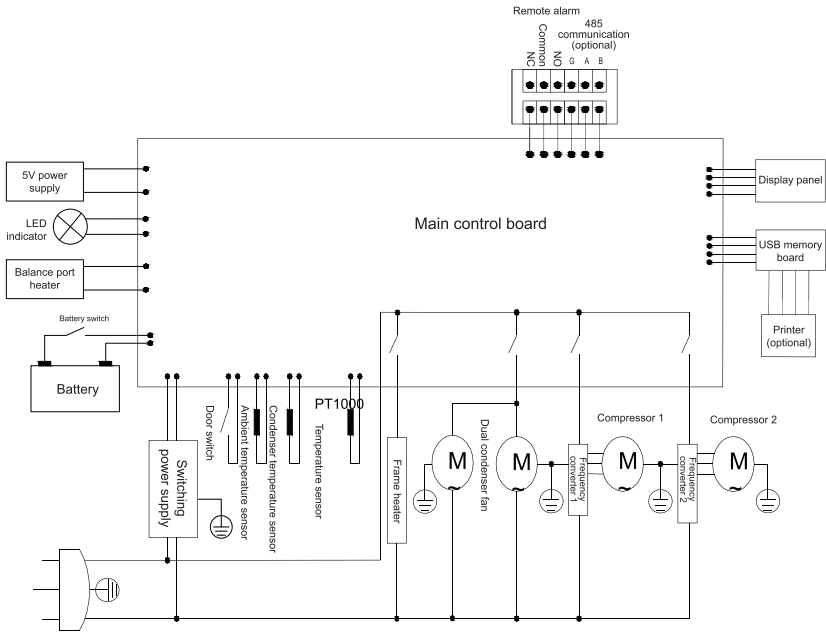

Note: For all models above, the functions of RS485 communication and USB memory board are alternative, with only one of them being selected.